

# VICTROLA™

by *innovative* technology.



## BLUETOOTH TURNTABLE WITH CD PLAYER

MODEL: VSC-551

### INSTRUCTION MANUAL

Please read this instruction manual carefully and keep it for future reference

# CONTENTS

Contents.....	1
Before Using the Unit.....	1
Safety Instructions.....	2
Proper Disc Use.....	3
Record Handling.....	3
Features and Functions.....	4
Replacing the Stylus.....	5
Record Operation.....	6
CD Operation.....	7
Bluetooth Operation.....	9
Troubleshooting.....	10
Specifications.....	11
FCC Statement, Prop 65 Warning, Warranty.....	12

## BEFORE USING THE UNIT

- As the unit may become warm during operation, always leave sufficient space around the unit for ventilation.
- The voltage supplied to the unit should match the voltage printed on the rear panel. If you are in any doubt regarding this matter, consult an electrician.
- Choose the installation location of your unit carefully. Avoid placing it in direct sunlight or close to a source of heat. Also, avoid locations subject to vibrations and excessive dust, heat, cold or moisture.
- Do not place the unit on an amplifier/receiver.
- Do not open the cabinet as this might result in damage to the circuitry and may cause electrical shock. If a foreign object should get into the unit, contact a service company.
- When removing the power plug from the wall outlet, always pull directly on the plug, never pull from the cord.
- To keep the CD laser pickup clean, be sure not to touch it. Always close to disc tray after inserting or removing a CD.
- Do not attempt to clean the unit with chemical solvents as this might damage the finish. Use a clean, dry cloth.
- Keep this manual in a safe place for future reference.
- **DO NOT MOVE THE UNIT DURING PLAYBACK:** During playback, the disc rotates at high speed. Do NOT lift or move the unit during playback. Doing so may damage the disc or the unit.

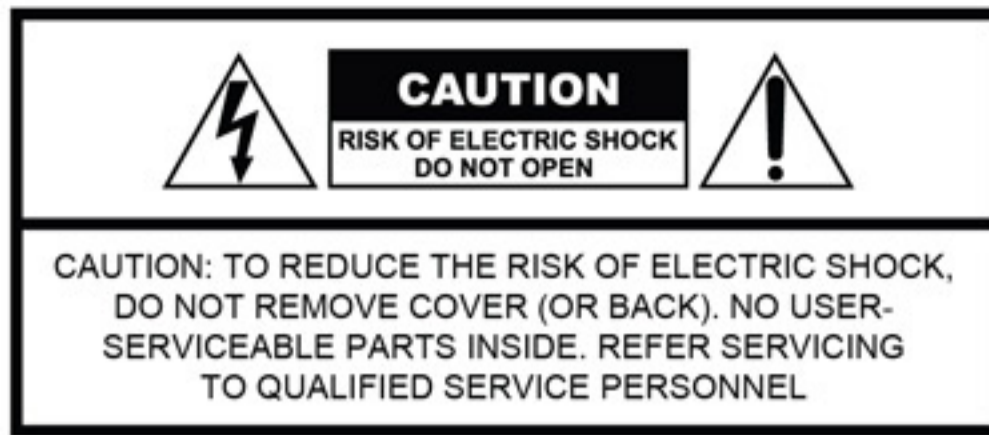

The lightning flash with arrowhead symbol, within an equilateral triangle, is intended to alert the user to the presence of uninsulated "dangerous voltage" within the product's enclosure that may be of sufficient magnitude to constitute a risk of electric shock to persons.



The exclamation point within an equilateral triangle is intended to alert the user to the presence of important operating and maintenance (servicing) instructions in the literature accompanying the appliance.

**WARNING: TO PREVENT FIRE OR SHOCK HAZARD. DO NOT EXPOSE THIS APPLIANCE TO RAIN OR MOISTURE.**

### **CAUTION**

1. DO NOT REMOVE THE EXTERNAL CASES OR CABINETS TO EXPOSE THE ELECTRONICS. NO USER SERVICEABLE PARTS ARE LOCATED INSIDE THE UNIT.
2. USE OF CONTROLS, ADJUSTMENTS OR PERFORMANCE PROCEDURES OTHER THAN THOSE SPECIFIED, MAY RESULT IN HAZARDOUS RADIATION EXPOSURE.

### **CAUTION**

The product should not be exposed to moist areas where water can drip or splash on the unit. Objects filled with liquids, such as vases, should NOT be placed on the product.

Do not install this equipment in a confined space such as a book case, small cabinet, etc.

## PROPER DISC USE

- **Discs which can be played on this unit:**

- Conventional audio CDs bearing the CD-DA logo on the label:
- Properly finalized CD-R and CD-RW discs.



- Always place the disc on the disc tray with the label side up.
- To remove a disc from its storage case, press down on the center of the case and lift the disc out, holding it carefully by the edges.



*How to Remove the Disc*



*How to Hold the Disc*

- Should the disc become dirty, wipe the surface radially (from the center hole outward towards the outer edge) with a soft, dry cloth.



- Never use such chemicals as record sprays, antistatic sprays or fluid, benzine or thinner to clean the discs. Such chemicals will do irreparable damage to the disc's plastic surface.
- Discs should be returned to their cases after use to avoid dust and scratches that could cause the laser pickup to "skip."
- Do not expose discs to direct sunlight or high humidity and temperature for extended periods. Long exposure to high temperatures will warp the disc.
- Do not play any disc that is warped, deformed or damaged. Playing such discs may cause irreparable harm to the playing mechanisms.
- CD-R and CD-RW discs are more sensitive to the effects of heat and ultraviolet rays than ordinary CDs. It is important that they are not stored in a location where direct sunlight will shine on them and away from sources of heat such as radiators or heat-generating electrical devices.
- Do not stick papers or protective sheets on the discs and do not use any protective coating spray.

## RECORD HANDLING

- Do not touch the grooves on the record. Only handle records by the edges or the label. Make sure your hands are clean. Skin oils from even clean hands can leave a residue on the record surface that will gradually deteriorate the quality of your record.

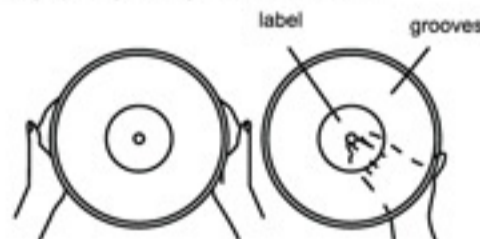

- Keep your records away from dust. Keep them in a cool, dry place.
- To avoid dust and scratches, keep records in the sleeves and jackets when not in use.
- Do not expose records to direct sunlight or high humidity and temperature. Long exposure to high temperatures will warp the record.
- Should the record become dirty, gently wipe the surface in a circular motion, using a soft anti-static cloth.



# FEATURES AND FUNCTIONS

- |                                   |                          |
|-----------------------------------|--------------------------|
| 1 DC-12V Input                    | 10 PROGRAM button        |
| 2 Line out                        | 11 STOP button           |
| 3 Speaker                         | 12 PLAY/PAUSE button     |
| 4 CD tray                         | 13 REPEAT button         |
| 5 CD Cover (with OPEN mark)       | 14 SPEED selector switch |
| 6 +10 button                      | 15 Function switch       |
| 7 DN/FR (Down/Fast Rewind) button | 16 POWER ON/OFF button   |
| 8 RANDOM button                   | 17 LED display           |
| 9 UP/FF (UP/Fast Forward) button  | 18 Volume knob           |

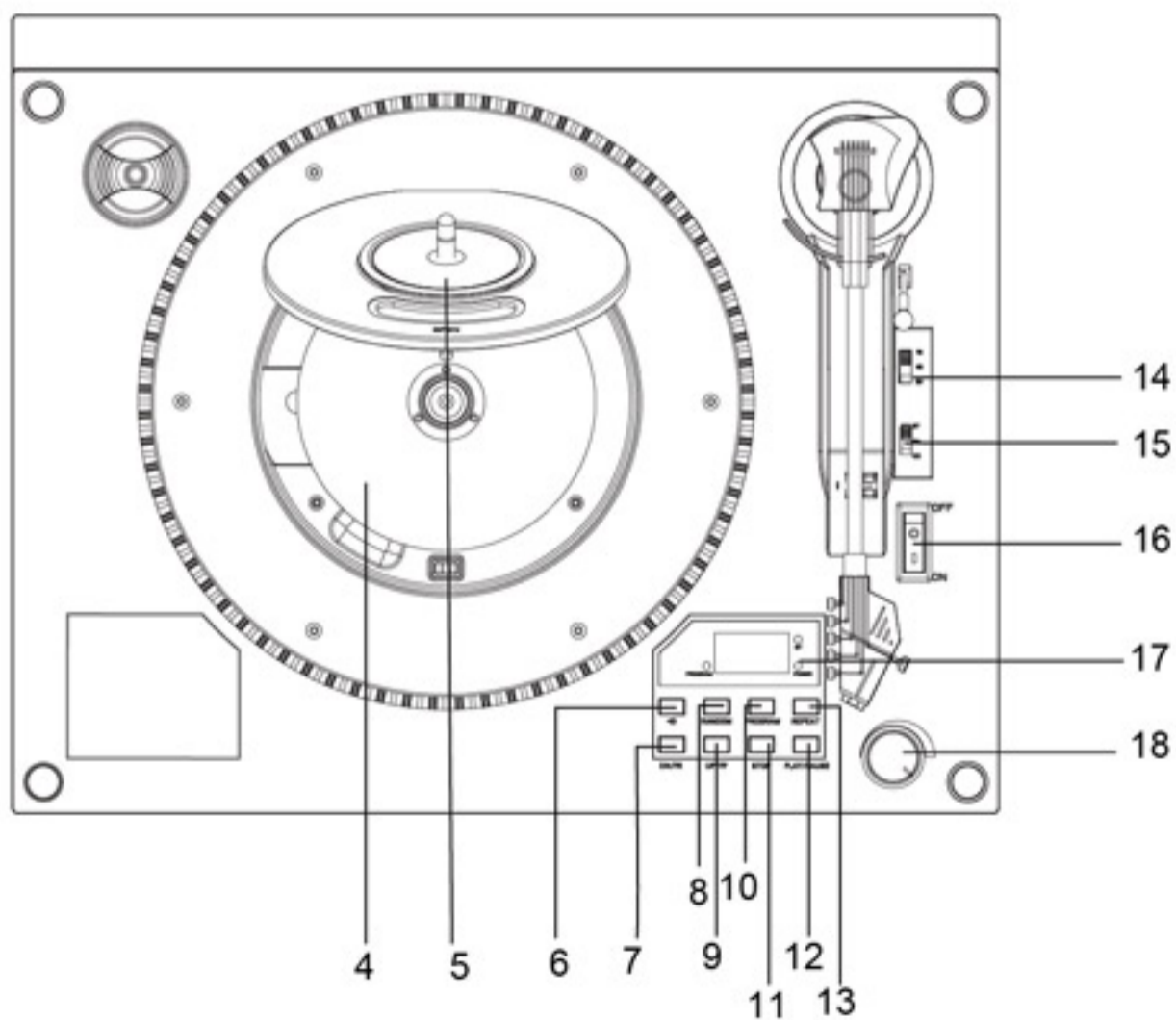
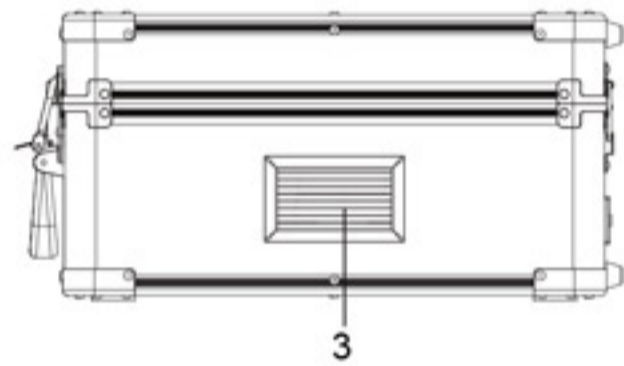
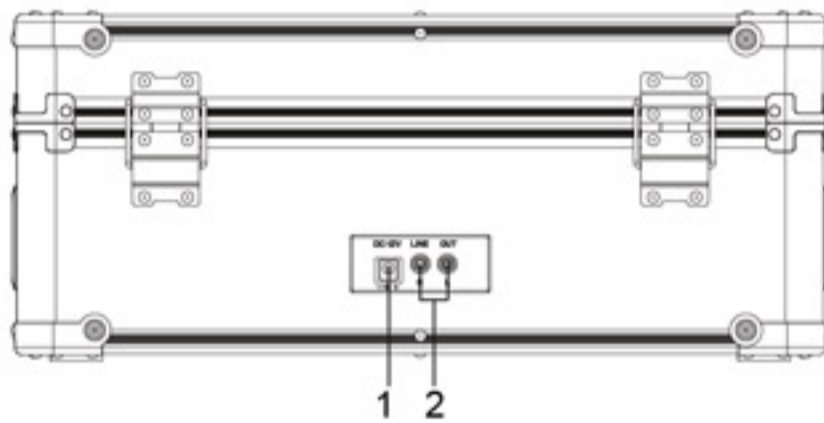

## REPLACING THE STYLUS

Under normal use, the stylus (needle) will last. However, it is recommended that the stylus be replaced as soon as you notice a change in sound quality. Prolonged use of a worn-out stylus may damage the record. The higher speed of 78 RPM records can wear the stylus at a faster rate.

### Caution:

- Do not remove or bend the stylus.
- To avoid injury, do not touch the needle.
- Turn off the unit's power before you replace the stylus.
- Keep out of the reach of children.

### Removing an old stylus:

1. Set a screwdriver at the tip of the stylus and push down to the direction "A".

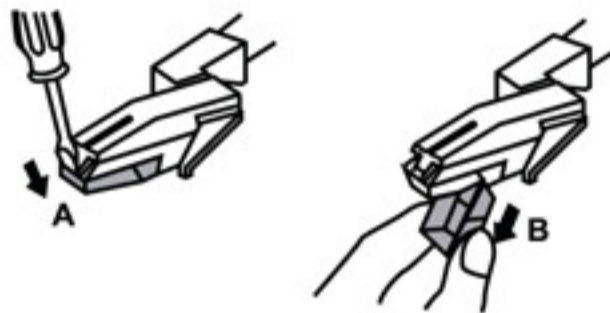

2. Pull the stylus out toward direction "B"

### Installing a new stylus

1. Hold the tip of the stylus and insert the other edge by pressing toward direction "C".
2. Push the stylus up toward direction "D" until it locks at the tip.

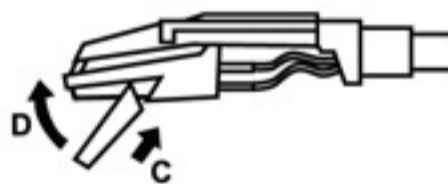

## RECORD OPERATION

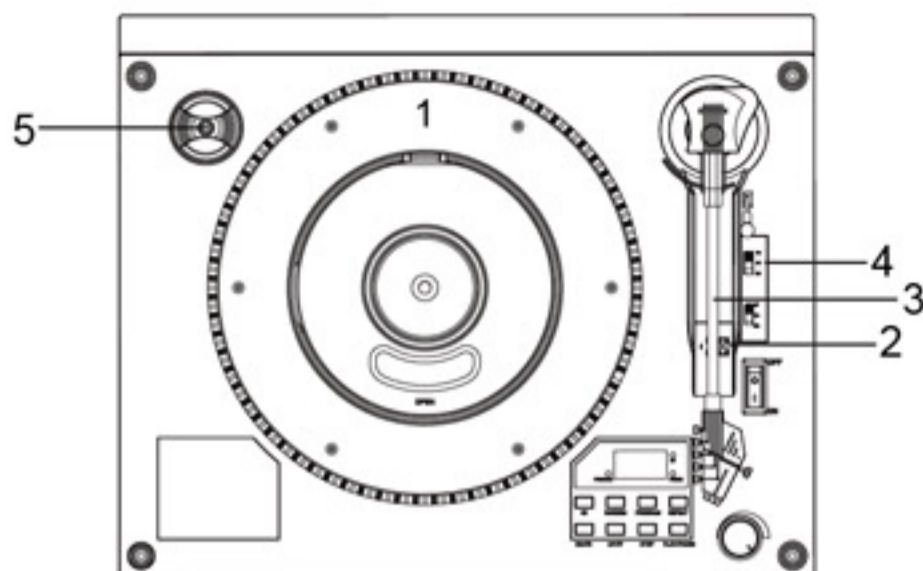

Before use, detach the stylus guard (white plastic cover) by pulling it straight off the front of the cartridge in the direction of the arrow.



1 Turntable

3 Tone Arm

5 45RPM Adapter

2 Tone Arm Holder

4 3-Speed Selector

### RECORD OPERATION

1. PUSH the ON/OFF POWER button to turn the unit On.

2. Set the function switch (BT/PH/CD) to the PH position.

3. Select the Record Speed using the 3-SPEED SELECTOR

**NOTE:** For a 45RPM record, please use included 45 Adaptor located in the top left corner of the unit.

4. Unlock the tone arm from the tone arm support.

5. Move the tone arm gently to the edge of the record (or the starting point of a track).

- The turntable will begin to turn. Be sure the stylus (needle) is secure.

- When the tone arm reaches the end of the record it will automatically stop.

Please manually return the tone arm back to the hold position.

6. Turn the VOLUME KNOB to adjust the volume.

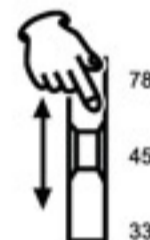

## CD OPERATION

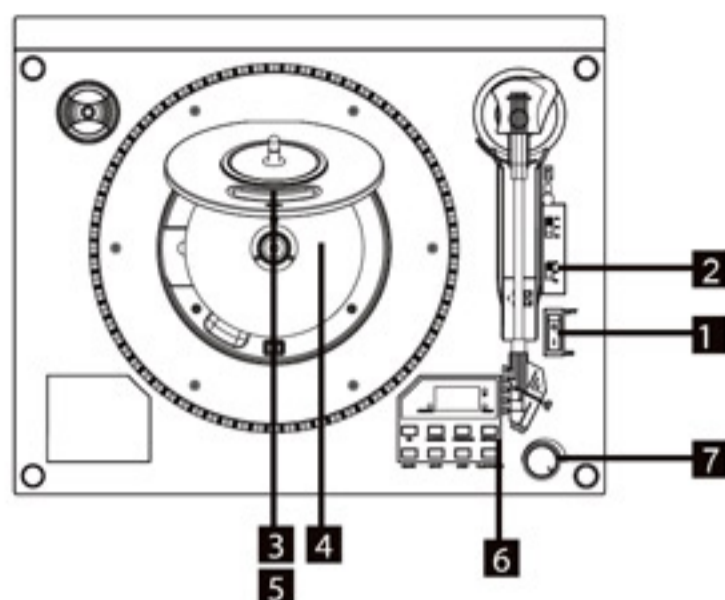

1. PUSH the POWER ON/OFF button to turn the unit On.



2. Set the function switch (BT/PH/CD) to CD position.

3. Press the OPEN on the CD cover to open the CD tray.

4. Place a disc on the tray with the printed label facing up.

NOTE: Never place more than one disc on the tray.

5. Close the CD cover. When the CD begins playing the LCD Display will show the total number of tracks.

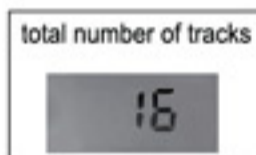

6. The unit will Start Playback Automatically.



7. Turn the VOLUME knob to adjust the volume.





## CD OPERATION

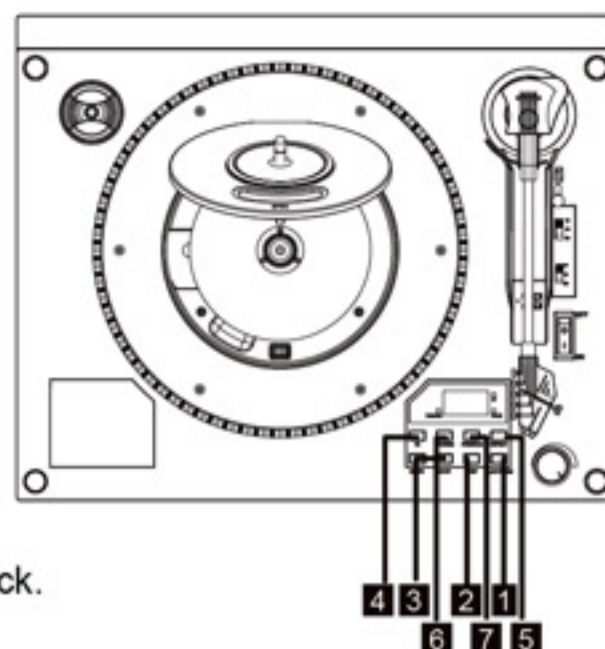

### 1. PAUSE/PLAY BUTTON

- Temporarily starts / stops CD playback.

### 2. STOP BUTTON

- Stops CD playback.

### 3. DN/FR or UP/FF BUTTON (PREVIOUS or SKIP Track)

- Press the DN/FR Button repeatedly to select a Previous Track.
- To Restart the Track Press the DN/FR Button once.
- To Skip a Track Press the UP/FF Button.
- Press the PLAY/PAUSE button within 5 seconds to start playing the selected track.

### 4. +10 BUTTON

- Press to skip 10 tracks at a time.

### 5. REPEAT BUTTON

- Press once to repeat one single track.
- Press twice to repeat all tracks.
- Press one more time to cancel the repeat function.

### 6. RANDOM BUTTON

- Shuffles each track during CD playback.
- Press the RANDOM button once and unit will play the tracks randomly.
- Press the DN/FR or UP/FF button to play the next tracks in a random order.
- Press the RANDOM button again to cancel the random function.

### 7. PROGRAM BUTTON

1. Stop CD playback, then press PROGRAM to set your own playlist on the CD.
  - Once pressed, the "PROGRAM" LED indicator will begin to flash while the display will show "P01".
2. Use the DN/FR & UP/FF buttons to select your first desired track.
  - Then press the PROGRAM button to save it as the first programmed song.
  - To save another track, repeat steps 1 & 2 above for each. Once a track is Programmed the "PROGRAM" LED Indicator will remain lit on that track.
3. The unit can program up to 20 tracks. To listen to the Programmed tracks, use the PLAY/PAUSE & STOP Buttons normally.
  - Press the STOP button twice on a selected programmed track to erase it, the "PROGRAM" LED Indicator will then turn off.
  - If the power is turned off or the function knob is set to other modes (BT/PHONO/CD), the programmed tracks will automatically be erased.

## BLUETOOTH OPERATION

An external device with Bluetooth Connectivity can be wirelessly connected to this turntable using the Bluetooth function.

1. Push the POWER ON/OFF Button to turn the unit On.
2. Turn the function switch (BT/PH/CD) to the BT (Bluetooth®) position, the blue LED light will begin to flash.
3. Turn your external device's Bluetooth Setting ON. Wait a moment, then look for the Bluetooth pairing name "VSC-551".
4. Select the Bluetooth pairing name, to connect the unit. Once connected, the blue LED will stop flashing. If you are asked for a passcode, enter "0000" to connect to the unit.
5. You are now connected to your external device via Bluetooth.
6. Rotate the VOLUME CONTROL KNOB to adjust the sound level.

### Note:

1. Make sure your Bluetooth device and this unit are within approximately 30 ft. from each other.
2. Check and see if there are other Bluetooth devices nearby interfering with the signal and connection.
3. This unit can be paired with multiple different Bluetooth devices, but can only be connected and played by one of them at a time. Make sure other devices are disconnected when you are trying to connect the one you are working on.

## **TROUBLESHOOTING**

**IF YOU EXPERIENCE ANY PROBLEMS WITH THE UNIT, PLEASE TAKE A MOMENT TO LOOK THROUGH THIS CHART AND SEE IF ANY OF THE PROBLEMS CAN BE SOLVED BEFORE CONTACTING CUSTOMER SERVICE.**

### **NO POWER**

- Check the connection to the AC power source. Check and make sure the AC source is not operated by a wall switch and if it is that the switch is turned on.
- Make sure there is power to the AC outlet by plugging in and testing with another item such as a lamp or fan.

### **NO SOUND**

- Adjust the volume using the VOLUME KNOB.

### **THERE IS STATIC WHEN PLAYING MUSIC**

- The unit may be too close to a TV set or similar appliance.
- Relocate the unit further away from the appliance, or turn all other appliances off.

### **RECORD PLAYER WILL NOT PLAY**

- Turn the VOLUME knob clockwise, and turn the function to PH mode.
- Detach the stylus guard. (The stylus guard is a white plastic cover that protects the stylus during transportation.) Failing to remove this guard will not allow the needle to contact the grooves of the record and no sound will be heard.
- If the stylus is worn out, change the stylus. Select the correct playback speed.

### **RECORD / CD IS SKIPPING**

- Place the unit on a stable surface to avoid vibration and shock. Make sure the unit is level both front to back and side to side. Clean the surface of the record/disc. Don't use scratched, damaged or warped records/discs.

### **CD PLAYER WILL NOT PLAY**

- Turn the VOLUME knob clockwise, and turn the function to CD mode.
- Load a disc with the artwork facing up and playback side facing down.
- If the disc is dirty, clean the surface of the disc.
- Make sure the disc is NOT a blank disc or a prerecorded CD-R/CD-RW.
- The unit will NOT play unfinalized CD-R/CD-RW discs.
- Finalize a CD-R/CD-RW disc in a CD recorder and try again.

### **BEWARE OF CONDENSATION**

When the unit (or a record/disc) is moved from a cold to a warm place, or used after a sudden temperature change, there is the danger of condensation. Vapor in the air could condense on the internal mechanism, making correct operation erratic or impossible. To prevent this, or if this occurs, leave the unit turned off for one or two hours.

### **MAINTENANCE - IF NORMAL OPERATION CANNOT BE OBTAINED, UNPLUG THE POWER CORD FROM THE OUTLET AND PLUG IT IN AGAIN.**

Always keep the turntable clean. If the surface of the unit gets dirty, wipe with a soft cloth or use a diluted mild liquid soap. Be sure to remove any excess liquid completely. Do not use thinner, benzine or alcohol as they may damage the surface of the unit. Allow the surface of the unit to dry completely before using.

# SPECIFICATIONS

## Amplifier

Output Power.....3W\*2  
Frequency Response.....50 Hz ~20KHz

## CD Player Section

Frequency Response.....20Hz to 20.000 Hz(±1dB)

## Record Player

Motor.....DC servo motor  
Drive System.....Belt Drive  
Speed.....33-1/3 rpm, 45 rpm, 78 rpm  
Wow and Flutter.....less than 0.25%(WDT)  
Cartridge type.....Ceramic Stereo Cartridge

## Speaker System

Unit.....1-way  
Impedance.....4 Ohms

## General

Power Requirements .....DC 12V  
Power Consumption.....19W  
Dimensions (W x H xD)...16-1/2" x 6-7/8" x 20-5/8"  
Weight.....20 lbs.

## Standard Accessories

Owner's Manual x 1  
12V 2A AC/DC adapter x 1

**PLEASE CONTACT CUSTOMER SERVICE  
FOR REPLACEMENT STYLUS AT  
[www.ithomeproducts.com/support](http://www.ithomeproducts.com/support)**

## FCC STATEMENT

Warning: Changes or modifications to this unit not expressly approved by the party responsible for compliance could void the user authority to operate the equipment.

NOTE: This equipment has been tested and found to comply with the limits for Class B digital device, pursuant to part 15 of the FCC Rules. These limits are designed to provide reasonable protection against harmful interference in a residential installation. This equipment generates, uses and can radiate radio frequency energy and, if not installed and used in accordance with the instructions, may cause harmful interference to radio or television reception, which can be determined by turning the equipment off and on, the user is encouraged to try to correct the interference by one or more of the following measures:

- Reorient or relocate the receiving antenna.
- Increase the separation between the equipment and the receiver.
- Connect the equipment into an outlet on a circuit different from that to which the receiver is connected.
- Consult the dealer or an experienced radio/TV technician for help.

## CALIFORNIA PROP 65 WARNING

"WARNING" This product contains a chemical known to the State of California to cause birth defects or other reproductive harm. For more information on these regulations and a list of chemicals, log on the following website address:

<http://www.oehha.ca.gov/prop65.html>

## WARRANTY

**Victrola is a registered trademark of Innovative Technology Electronics Corp.**

**Innovative Technology Electronics Corp.**

**Limited Warranty: 90 Days Labor, One Year Parts**

Innovative Technology Electronics Corp. (IT) warrants the product to be free from "Defects" in materials under normal use for a period of "One Year" from the date of the original purchase. The Warranty is "Not" transferable. IT agrees, within the initial "90 Day" period, to repair or replace the product if it is determined to be defective at "No Charge". It is further agreed that IT will cover the cost to repair or replace damaged "Parts" only for a total period of "One Year" from the date of the original purchase. The warranty does not cover cosmetic damage, antennas, AC cords, cabinets, headbands, ear-pads, or damage due to line power surges, connection to improper voltage supply or settings, misuse, mishandling, accident, acts of God or attempted repair by an unauthorized service agent.

**To obtain service, the purchaser MUST present an original sales receipt / proof of purchase.**

**Please contact us at [www.ithomeproducts.com](http://www.ithomeproducts.com) to request an RMA (Return Material**

**Authorization) number to return products for service or replacement.** Returns without an RMA number on the package will be refused and returned to sender. Upon receipt of the returning item and our full inspection (IT) may issue a replacement to customer for the same item or of one that has equivalent value and features. To return an item, supply full name, return address, phone number, item purchased, receipt of purchase and reason for return to obtain RMA number.

All returns must be in the original packaging or reasonable substitute to prevent damage. Customer "Must" include full name, shipping address and telephone number inside of package. No return will be shipped back to a PO Box or APO address.

Please include your check or money order in the amount of:

- **USD \$5.00 for items \$10.00 to \$39.99 (Price Paid Per Unit)**
- **USD \$10.00 for items \$40.00 to \$99.99. (Price Paid Per Unit)**
- **USD \$16.00, for items \$100.00 and up. (Price Paid Per Unit)**
- **Shipping fees are non-refundable**

to be payable to Innovative Technology Electronics Corp. (for handling and return shipping charges) (IT) will not be responsible for delays or unprocessed claims resulting from a purchaser's failure to provide any / all of the necessary information. Send all inquiries or RMA request via our website [www.ithomeproducts.com/support](http://www.ithomeproducts.com/support).

Innovative Technology Electronics Corp.

1 Channel Drive

Port Washington, NY 11050

Toll free: 1-877-483-2497

Website for support: [www.ithomeproducts.com/support](http://www.ithomeproducts.com/support)

There are no express warranties except as listed above.

REPAIR OR REPLACEMENT AS PROVIDED UNDER THIS WARRANTY IS THE EXCLUSIVE REMEDY OF THE CUSTOMER, (IT) SHALL NOT BE LIABLE FOR ANY INCIDENTAL OR CONSEQUENTIAL DAMAGES FOR BREACH OF ANY EXPRESS OR IMPLIED WARRANTY ON THIS PRODUCT EXCEPT TO THE EXTENT PROHIBITED BY APPLICABLE LAW. ANY IMPLIED WARRANTY OF MERCHANTABILITY OR FITNESS FOR A PARTICULAR PURPOSE ON THIS PRODUCT IS LIMITED IN DURATION TO THE DURATION OF THIS WARRANTY.

Some states do not allow the exclusion or limitation of incidental or consequential damages, or limitations on how long an implied warranty lasts, so the above exclusions or limitations may not apply to you. This warranty gives you specific legal rights and you may also have other rights, which vary from state to state.

Made In China.